

| ★ | SHOT PUT [Summary of Rules] | 2026 |
|------------------------------------------------------------------------------------------------------------|-----------------------------|---------------------|
| IMPLEMENTS: | | p.43 |
| 1) Boys: Shot Put = 12 lb; Girls: Shot Put = 4 Kg. | | 6-10-2 |
| 2) Shot Puts may not have indentations other than a weight marking. | | 6-10-1 |
| 3) Illegal equipment is not allowed during warm-up or competition. If used ➔ Event DQ. | | 6-2-13 |
| UNIFORMS: | | p.23-24 |
| 4) Competitors must wear shoes fastened securely to both feet. | | 4-3-1a |
| 5) Competitors must compete in a complete uniform (school issued or school approved). | | 4-3-1b |
| WARM-UP: | | p.42 |
| 6) Warm-up must be supervised by official or coach and venue declared open. | | 6-2-6 |
| 7) Once competition begins, venue and associated equipment is off limits for practice. | | 6-2-8 |
| 8) Event concluded - there will be no further activity - event area is closed. | | 6-2-9 |
| 1st Violation ➔ Warning 2nd Violation ➔ Event DQ 3rd Violation ➔ Meet DQ | | |
| ORDER: Boys 1st [even year] ➔ Girls 1st [odd year] | | p.44 |
| 9) Open order: The GAMES COMMITTEE will set time limit for prelims. [3-2-4d] | | 6-2-21 |
| 10) Prelim flights of 5 or more by lot or by the order set by the GAMES COMMITTEE. | | 6-2-18 |
| 11) Finals: Worst prelim mark is 1st; Athlete w/best prelim mark is last. [6-2-3] | | 6-2-20 |
| 12) Order may be changed in SHOT PUT to allow for participation in other events. | | 6-2-3 |
| GRIP: | | p.43; 45 |
| 13) Chalk or an adhesive such as rosin may be used to assist with grip. | | 6-2-14 |
| 14) Gloves NOT permitted; Taping adjacent fingers independently, permitted. | | 6-4-1 |
| 15) Taping of the wrist (no stiff support), wrist wrap and/or support belt is permitted. | | 6-4-1 |
| TRIALS: | | p.42 |
| 16) Larger meets: 3 prelims + 3 finals: all trials count for placing. | | 6-2-17 |
| 17) Smaller meets: 4 trials ➔ no finals: all trials count for placing. [3-2-4e] | | 6-2-10 |
| TIME LIMIT TABLE: | | p.41; 45; 42 |
| 18) After being called competitors have one (1) min to initiate a trial. [6-2-2] | | 6-4-3a |
| 19) Competitor is signaled when 15 sec remain in time allowed. | | 6-2-2f |
| 20) Time limit when excused to other events ➔ determined by GAMES COMMITTEE. | | 6-2-4 |
| MEASUREMENTS: | | p.52; 46 |
| 21) Marks are recorded after each LEGAL trial; ONLY measure LEGAL trials. | | Mhsaa |
| 22) SECTOR LINES are out-of-bounds. Puts shall be made from inside the circle. | | 6-9-2 |
| 23) Measure from nearest edge of mark to inside edge of stopboard thru center of circle. | | 6-4-4 |
| 24) RECORD LEGAL TRIALS to nearest lesser quarter (¼) INCH or CENTIMETER. | | 6-4-5 |
| FINALS: | | p.44 |
| 25) One (1) more competitor advances to finals than places awarded - no substitutions. | | q.2-1 |
| 26) Ex. If 8 places score, 9 competitors advance to finals + EVERYONE tied for 9th. | | 6-2919 |
| 27) There must be at least one qualifying prelim trial for athlete to move on to finals. | | 6-2-19 |
| FAILED ATTEMPTS: | | p.45-46 |
| 28) FAILS TO INITIATE A TRIAL within one (1) min after name is called. [6-2-2] | | 6-4-3a |
| 29) Once in the circle, Competitor FAILS TO PAUSE before starting the put. | | 6-4-3b |
| 30) TOUCHES TOWBOARD TOP or ANY SURFACE outside of circle during the put. | | 6-4-3ce |
| 31) The SHOT DROPS BEHIND OR BELOW the shoulder. | | 6-4-3d |
| 32) A legal put must be made from shoulder with ONE HAND ONLY from inside the circle. | | 6-4-2 |
| 33) Shot does not fall WITHIN the sector lines. | | 6-4-3f |
| 34) Competitor LEAVES THE CIRCLE BEFORE the implement has landed. | | 6-4-3g |
| 35) Competitor DOES NOT EXIT BACK HALF of the circle. [NOTE: Competitor may enter circle from anywhere] | | 6-4-3h |
| 36) Competitor does a "CARTWHEEL." | | 6-4-3i |
| TIES: | | p.44 |
| 37) Break ties by comparing 2nd-best efforts. CONSIDER ALL TRIALS. | | 6-3-2a1 |
| 38) If still tied after comparing 2nd-best effort, compare 3rd-best efforts, etc. | | 6-3-2a2 |

| ★ | DISCUS THROW [Summary of Rules] | 2026 |
|------------------------------------------------------------------------------------------------------------|---------------------------------|---------------------|
| IMPLEMENTS: | | p.62 |
| 1) Boys: Discus = 1.6 Kg; Girls: Discus = 1 Kg. | | 6-10-4 |
| 2) A Discus may not have indentations, projecting points or sharp edges. | | 6-10-3 |
| 3) Illegal equipment is not allowed during warm-up or competition. If used ➔ Event DQ. | | 6-2-13 |
| UNIFORMS: | | p.23-24 |
| 4) Competitors must wear shoes fastened securely to both feet. | | 4-3-1a |
| 5) Competitors must compete in a complete uniform (school issued or school approved). | | 4-3-1b |
| WARM-UP: | | p.42 |
| 6) Warm-up must be supervised by official or coach and venue declared open. | | 6-2-6 |
| 7) Once competition begins, venue and associated equipment is off limits for practice. | | 6-2-8 |
| 8) Event concluded - there will be no further activity - event area is closed. | | 6-2-9 |
| 1st Violation ➔ Warning 2nd Violation ➔ Event DQ 3rd Violation ➔ Meet DQ | | |
| ORDER: Girls 1st [even year] ➔ Boys 1st [odd year] | | p.44 |
| 9) Open order: Games committee will set time limit for prelims. [3-2-4d] | | 6-2-21 |
| 10) Prelim flights of 5 or more by lot or by the order set by the GAMES COMMITTEE. | | 6-2-18 |
| 11) Finals: Worst prelim mark is 1st; Athlete w/best prelim mark is last. [6-2-3] | | 6-2-20 |
| 12) Order may be changed in DISCUS to allow for participation in other events. | | 6-2-3 |
| GRIP: | | p.43; 45 |
| 13) Chalk or an adhesive such as rosin may be used to assist with grip. | | 6-2-14 |
| 14) Gloves NOT permitted; Taping adjacent fingers independently, permitted. | | 6-4-1 |
| 15) Taping of the wrist (no stiff support), wrist wrap and/or support belt is permitted. | | 6-4-1 |
| TRIALS: | | p.42-43 |
| 16) Larger meets: 3 prelims + 3 finals: all trials count for placing. | | 6-2-17 |
| 17) Smaller meets: 4 trials ➔ no finals: all trials count for placing. [3-2-4e] | | 6-2-10 |
| TIME LIMIT TABLE: | | p.41; 45; 42 |
| 18) After being called competitors have one (1) min to initiate a trial. [6-2-2] | | 6-4-3a |
| 19) Competitor is signaled when 15 sec remain in time allowed. | | 6-2-2f |
| 20) Time limit when excused to other events ➔ determined by GAMES COMMITTEE. | | 6-2-4 |
| MEASUREMENTS: | | p.52; 45 |
| 21) Marks are recorded after each LEGAL trial; ONLY measure LEGAL trials. | | Mhsaa |
| 22) SECTOR LINES are out-of-bounds. Puts shall be made from inside the circle. | | 6-9-2 |
| 23) A discus that hits the CAGE or OBJECT outside the sector is a foul. | | 6-5-2e |
| 24) Measure from nearest edge of mark to inside edge of circle through its center. | | 6-5-3 |
| 25) RECORD LEGAL TRIALS to nearest lesser WHOLE INCH or CENTIMETER. | | 6-5-4 |
| FINALS: | | p.43 |
| 26) One (1) more competitor advances to finals than places awarded - no substitutions. | | 6-2-19 |
| 27) Ex. If 8 places score, 9 competitors advance to finals + EVERYONE tied for 9th. | | 6-2-19 |
| 28) There must be at least one qualifying prelim trial for athlete to move on to finals. | | 6-2-19 |
| FAILED ATTEMPTS: | | p.46 |
| 29) FAILS TO INITIATE A TRIAL within one (1) min after name is called. [6-2-2] | | 6-5-2a |
| 30) Once in the circle, Competitor FAILS TO PAUSE before starting throw. | | 6-5-2b |
| 31) Competitor TOUCHES any surface outside of circle during throw. | | 6-5-2c |
| 32) Discus does not fall WITHIN the sector lines. | | 6-5-2d |
| 33) Discus hits the cage or object outside the sector and bounces back into the sector. | | 6-5-2e |
| 34) Competitor LEAVES THE CIRCLE BEFORE the implement has landed. | | 6-5-2f |
| 35) Competitor DOES NOT EXIT BACK HALF of the circle. [NOTE: Competitor may enter circle from anywhere] | | 6-5-2g |
| TIES: | | p.44 |
| 35) Break ties by comparing 2nd-best efforts. CONSIDER ALL TRIALS. | | 6-3-2a1 |
| 36) If still tied after comparing 2nd-best effort, compare 3rd-best efforts, etc. | | 6-3-2a2 |
| 37) Ties remaining after this process - Add points for places & divide between competitors. | | 6-3-2a4 |

| ★ | LONG JUMP [Summary of Rules] | 2026 |
|-------------------------------------------------------------------|----------------------------------------------------------------------------------------------------------------------------------------------|---------|
| LANDING AREA: p.56-57 | | |
| 1) | Take-off board shall be 8" (recommended) to 24" deep and 42" to 48" wide. | 6-9-15 |
| 2) | The landing area should be filled with 12" sand & level with the board. | 6-9-16 |
| 3) | The landing area shall be a minimum of 23' long and 9' wide. | 6-9-17 |
| 4) | Distance from the foul line to pit may be adjusted to accommodate levels of ability. | 6-9-17 |
| UNIFORMS: p.23-24 | | |
| 5) | Competitors must wear shoes fastened securely to both feet. | 4-3-1a |
| 6) | Competitors must compete in a complete uniform (school issued or school approved). | 4-3-1b |
| WARM-UP: p.42 | | |
| 7) | Warm-up must be supervised by official or coach and venue declared open. | 6-2-6 |
| 8) | Warm-up approaches shall only be run in the direction of competition. [see NOTE] | 6-2-7 |
| 9) | Once competition begins, venue and equipment is off limits for practice. | 6-2-8 |
| 10) | Event concluded - there will be no further activity - event area is closed. | 6-2-9 |
| | 1st Violation ➔ Warning 2nd Violation ➔ Event DQ 3rd Violation ➔ Meet DQ | |
| ORDER: Girls 1st [even year] ➔ Boys 1st [odd year] p.41-44 | | |
| 11) | Open order: GAMES COMMITTEE will set time limit for prelims. [3-2-4d] | 6-2-21 |
| 12) | Prelim flights of 5 or more by lot or by the order set by the GAMES COMMITTEE. | 6-2-18 |
| 13) | Finals: Athlete w/least prelim jumps 1st; Athlete w/best prelim jumps last. [6-2-3] | 6-2-20 |
| 14) | Order may be changed in LONG JUMP to allow for participation in other events. | 6-2-3 |
| CHECK MARKS: p.13 | | |
| 15) | The type material used for check marks is determined by GAMES COMMITTEE. | 3-2-4b |
| 16) | Check marks are not allowed on the runway or in the landing pit. | 6-7-1 |
| 17) | ONE or TWO APPROVED markers may be placed alongside the runway. | 6-7-1 |
| TRIALS: p.43 | | |
| 18) | Larger meets: 3 prelims + 3 finals: all trials count for placing. | 6-2-17 |
| 19) | Smaller meets: 4 trials ➔ no finals: all trials count for placing. [3-2-4f] | 6-2-10 |
| TIME LIMIT TABLE: p.41-42; 47 | | |
| 20) | After being called competitors have one (1) min to initiate a trial. [6-2-2] | 6-7-3a |
| 21) | Competitor is signaled when 15 sec remain in time allowed. | 6-2-2f |
| 22) | Time limit when excused to other events ➔ determined by GAMES COMMITTEE. | 6-2-4 |
| FAILED ATTEMPTS: p.47 | | |
| 23) | Any part of the shoe violates the foul line. | 6-7-3b |
| 24) | Competitor runs through the foul line or foul line extended. | 6-7-3c |
| 25) | Competitor does not keep head in superior position. [NO somersault] | 6-7-3d |
| 26) | Competitor does not land in the pit. | 6-7-3f |
| 27) | When leaving the pit, competitor touches the ground outside the landing area closer to the foul line than the nearest mark made in the sand. | 6-7-3f |
| 28) | FAILS TO INITIATE A TRIAL within one (1) min after name is called. [6-2-2] | 6-7-3a |
| MEASUREMENTS: p.48 | | |
| 29) | Measure from nearest edge of landing mark perpendicularly to the foul line. | 6-7-4 |
| 30) | The foul line may need to be extended to ensure a perpendicular measurement. | 6-7-4 |
| 31) | Measurements of trials shall be taken at the takeoff board. | 6-7-5 |
| 32) | ONLY measure LEGAL trials. Record to nearest LESSER ¼ INCH or CENTIMETER. | 6-7-6 |
| FINALS: p.44 | | |
| 33) | One (1) more competitor advances to finals than places awarded - no substitutions. | 6-2-19 |
| 34) | Ex. If 8 places score, 9 competitors advance to finals + EVERYONE tied for 9th. | 6-2-19 |
| 35) | There must be at least one qualifying prelim trial for athlete to move on to finals. | 6-2-19 |
| TIES: p.44 | | |
| 36) | Break ties by comparing 2nd-best efforts. CONSIDER ALL TRIALS. | 6-3-2a1 |
| 37) | If still tied after comparing 2nd-best effort, compare 3rd-best efforts, etc. | 6-3-2a2 |
| 38) | Ties remaining after this process - Add points for places & divide between competitors. | 6-3-4 |

| ★ | HIGH JUMP [Summary of Rules] | 2026 |
|-----------------------------------------------------------------------------------------------|--------------------------------------------------------------------------------------------------------------------------------------------------------------------------------------------------------------------------------------|----------|
| LANDING AREA: p.57 | | |
| 1) | Landing pads in sections must be attached and encased in a COMMON COVER. | 6-9-20 |
| 2) | Bordering surfaces (concrete/asphalt) shall be padded 2" dense foam material. | 6-9-21 |
| 3) | Support bases shall be marked; plane of X-bar located \geq 4" from landing pad. | 6-9-22 |
| 4) | Mark the X-Bar and base of the standards to ensure consistent placement. | 6-9-22 |
| 5) | High Jump X-bar shall be circular, non-metal and 12' to 14'10" in length. | 6-9-23 |
| UNIFORMS: p.23-24 | | |
| 6) | Competitors must wear shoes fastened securely to both feet. | 4-3-1a |
| 7) | Competitors must compete in a complete uniform (school issued or school approved) | 4-3-1b |
| WARM-UP: p.42 | | |
| 8) | Warm-up must be supervised by official or coach and venue declared open. | 6-2-6 |
| 9) | Bungee cord X-bars may be used for warm-up jumps. | 6-8-3 |
| 10) | Once competition begins, venue and equipment is off limits for practice. | 6-2-8 |
| 11) | Event concluded - there will be no further activity - event area is closed. | 6-2-9 |
| | 1st Violation ➔ Warning 2nd Violation ➔ Event DQ 3rd Violation ➔ Meet DQ | |
| ORDER: Boys 1st [even year] ➔ Girls 1st [odd year] p.43; 48 | | |
| 12) | Calling contestants in listed order or using the "Five-Alive" system is allowed. | 6-8-2 |
| 13) | When less than 9 remain at a height, ALL will move to a single continuing flight. | 6-8-2 |
| 14) | Order may be changed in HIGH JUMP to allow for participation in other events. | 6-2-3 |
| CHECK MARKS: p.49 | | |
| 15) | GAMES COMMITTEE specifies location, marking material and number of check marks. | 6-8-7 |
| TRIALS: p.48-50 | | |
| 16) | Competitors receive a maximum of three (3) trials at each height in order of draw. | 6-8-1 |
| 17) | Trials may be passed. Only the number of attempts left will be available. | 6-8-1 |
| 18) | Once three (3) consecutive misses occur the contestant is eliminated from the event. | 6-8-1 |
| 19) | Warm-up for athlete(s) entering HJ after sixty (60) min have elapsed get 1-1/2 min to warm-up w/o crossbar or bungee at height change. If more than 1 athlete they each get 1-1/2 min; not aggregated, must make 1 attempt in 1 min. | 6-8-6 |
| 20) | Opening heights will be determined by the GAMES COMMITTEE. | 6-8-8 |
| 21) | When only one competitor remains, the winner may choose the next height. | 6-8-8 |
| 22) | An accurate measurement of the bar shall be taken before each record attempt. | 6-8-12 |
| 23) | Measurements shall be made to the nearest lesser (¼) INCH or CENTIMETER. | 6-8-13 |
| TIME LIMIT TABLE: One (1) min if entering competition for first time. [6-2-2d] p.41-42 | | |
| 24) | Competitors Initiate Trials: If \geq FOUR ➔ 1 min; If \leq THREE ➔ 3 min; If = ONE ➔ 5 min. | 6-2-2 |
| 25) | Competitor is signaled when 15 sec remain in time allowed. | 6-2-2f |
| 26) | Time limit when excused to other events ➔ determined by GAMES COMMITTEE. | 6-2-4 |
| FAILED ATTEMPTS: p.47 | | |
| 28) | Displaces X-bar during an attempt to clear. | 6-8-11a |
| 29) | Touches ground/landing area beyond plane of X-bar or its extension w/o clearing bar. | 6-8-11b |
| 30) | Clears height, then contacts upright and displaces (or steadies) X-bar. | 6-8-11c |
| 27) | FAILS TO INITIATE A TRIAL within time limit after X-bar is set and NAME is called. | 6-8-11d |
| 31) | Competitor fails (total body) to go over the X-bar. | 6-8-11e |
| 32) | Competitor takes off from two (2) feet. | 6-8-11f |
| GENERAL: p.49 | | |
| 33) | The X-bar shall not be lowered once the event begins except for a 1st place tie. | 6-8-9 |
| 34) | If a support is misplaced or slips, this is 'no jump' and another trial will be allowed. | 6-8-4 |
| 35) | A X-bar displaced by an external force after cleared legally is counted successful. | 6-8-5 |
| TIES: p.44 | | |
| 36) | 1st tie breaker: fewest number of misses at tied height is winner. | 6-3-2b1 |
| 37) | 2nd tie breaker: fewest number of misses during competition is the winner. | 6-3-2b2 |
| 38) | Passed trials shall not count as misses. | 6-3-2b3 |
| | 3rd tie breaker FOR 1st PLACE ONLY: Allow one (1) more trial at FAILED height. | 6-3-2b4a |
| 39) | Tied jumpers both miss ➔ lower the bar 1" (2 cm) and allow one (1) trial. | 6-3-2b4b |
| | Tied jumpers both clear ➔ raise the bar 1" (2 cm) and allow one (1) trial. | |
| | Continue to raise/lower the bar and allow one (1) trial until winner is determined. | |
| 40) | Ties BELOW 1st place: Add points for places; Divide by number of tied competitors. | 6-3-4 |

★ **POLE VAULT** [Summary of Rules - p. 1 of 2] **2026**

| | |
|----------------------------------------------------------------------------------------------------------------------------------------------------------------------------|-----------------------|
| LANDING AREA: | p.58-60 |
| 1) Landing pads in sections must be encased in a common cover. | 6-9-26 |
| 2) The maximum cutout for the planting box shall be 36" in width. | 6-9-27 |
| 3) Hard surfaces shall be padded with a min 2" of dense foam/suitable material. | 6-9-28 |
| 4) Support bases must be secured or weighted to prevent them from tipping over. | 6-9-29 |
| 5) Width between support pins is $\geq 13'8"$ and $\leq 14'8"$. | 6-9-29 |
| 6) Pole Vault X-bar shall be circular, non-metal and $\geq 14'8"$ and $\leq 14'10"$ in length. | 6-9-30 |
| 7) X-bar is placed 18" to 31½" beyond the stop board landing pit. [Fig 14] | 6-8-19 |
| UNIFORMS: | p.23-24 |
| 8) Competitors must wear shoes fastened securely to both feet. | 4-3-1a |
| 9) Competitors must compete in a complete uniform (school issued or school approved). | 4-3-1b |
| WARM-UP: | p.42; 43; 51 |
| 10) Pole vault warm-up may not start until poles have been inspected & approved for use. | 6-8-17 |
| 11) Bungee cord X-bar may be used for warm-up vaults. | 6-8-3 |
| 12) Warm-up must be supervised by official or coach and venue declared open. | 6-2-6 |
| 13) Warm-up approaches shall only be run in the direction of competition. [see NOTE] | 6-2-7 |
| 14) Once competition begins, venue and associated equipment is off limits for practice. | 6-2-8 |
| 15) Event concluded - there will be no further activity - event area is closed. | 6-2-9 |
| 16) Event concluded ALL associated equipment INCLUDING POLES is removed from area. 1st Violation → Warning 2nd Violation → Event DQ 3rd Violation → Meet DQ | 6-2-9 |
| ORDER: Girls 1st [even year] → Boys 1st [odd year] | p.42-49 |
| 17) Calling contestants in listed order or using the "Five-Alive" system is allowed. | 6-8-2 |
| 18) When less than 9 remain at a height, ALL will move to a single continuing flight. | 6-8-2 |
| 19) Order may be changed in POLE VAULT to allow for participation in other events. | 6-2-3 |
| POLES: | p.50 |
| 20) Poles may be of any material of any length or diameter. | 6-8-14 |
| 21) The plant end may be protected by TAPE LAYERS, PVC, spng. rubber, suitable material. Manufacturer's pole rating shall be a minimum of ¾-inch in a contrasting color | 6-8-14 |
| 22) located within or above top hand-hold position; a one 1-inch circular band placed by the manufacturer to indicate the top handhold position is required. | 6-8-15 |
| 23) Prior to competition, the coach must verify poles meet specifications and that the vaulter is using a pole rated \geq the vaulter's weight. | 6-8-15 |
| 24) Variable weight pole; mismarked pole; lighter rated pole → Illegal → Event DQ. | 6-8-16 |
| CHECK MARKS: | p.50 |
| 25) The type material used for check marks is determined by GAMES COMMITTEE. | 6-8-21 |
| GRIP: | p.50 |
| 26) Taping wrists is allowed. | 6-8-21 |
| 27) Tape NOT allowed on hand unless to cover an open wound. | 6-8-21 |
| 28) Gloves NOT allowed. The use of a forearm cover to prevent injuries is permitted. | 6-8-21 |
| 29) Chalk or an adhesive such as rosin may be applied to hands or pole. | 6-8-21 |
| 30) Tape on poles must be of UNIFORM THICKNESS below top hand hold mark. | 6-8-14 |
| TRIALS: | p.48-49; 51-52 |
| 31) Opening heights will be determined by GAMES COMMITTEE. | 6-8-18 |
| 32) When only one competitor remains, the winner may choose the next height. | 6-8-18 |
| 33) Competitors receive a max of three (3) trials at each height in order of draw. | 6-8-1 |
| 34) Trials may be passed. Only the number of attempts left will be available. | 6-8-1 |
| 35) Once three (3) consecutive misses occur the contestant is eliminated. | 6-8-1 |
| 36) A broken pole during an attempt does not count as a trial. | 6-8-22 |
| 37) A X-bar displaced by an external force after cleared legally is counted successful. | 6-8-5 |
| 38) An accurate measurement of the bar shall be taken before each record attempt. | 6-8-27 |
| 39) Measurements shall be made to the nearest lesser ¼ INCH or CENTIMETER. | 6-8-28 |
| TIME LIMIT TABLE: One (1) min if entering competition for first time. [6-2-2d] | p.41-42 |
| 40) Competitors Initiate Trials: If \geq FOUR → 1 min; If \leq THREE → 3 min; If = ONE → 5 min. | 6-2-2 |
| 41) Competitor is signaled when 15 sec remain in time allowed. | 6-2-2f |
| 42) Time limit when excused to other events → determined by GAMES COMMITTEE. | 6-2-4 |

★ **POLE VAULT** [Summary of Rules - p. 2 of 2] **2026**

| | |
|--------------------------------------------------------------------------------------------------------------------------------------------------------------------------------------------------------------------------------------------------------------------------------------------------------------------------------------|--------------------|
| FAILED ATTEMPTS: | p.52 |
| 43) Competitor displaces X-bar with body or pole during an attempt to clear. | 6-9-26b |
| 44) Competitor leaves ground and fails to clear. (excludes aborted approaches). | 6-9-26c |
| 45) Uppermost hand is raised above starting point when they leave the ground or lower hand moves above upper hand on the pole. | 6-9-26d |
| 46) Body/pole touches ground/landing area beyond plane of stop board before clearing. | 6-9-26e |
| 47) FAILS TO INITIATE A TRIAL within time limit after X-bar is set and NAME is called. | 6-8-26a |
| 48) Competitor clears the height, contacts upright and displaces or steadies X-bar. | 6-9-26fg |
| 49) Competitor grips the pole above the top circular band placed by the manufacturer. | 6-9-26h |
| 50) Competitor touches (or catches) pole to prevent it from dislodging X-bar. | 6-9-26i |
| GENERAL: | p.50-52; 49 |
| 51) No person except competitor, official or designee allowed to touch the pole. | 6-9-24 |
| 52) The X-bar shall not be lowered once the event begins except for a 1st place tie. | 6-9-25 |
| 53) Mark the X-Bar and base of the standards to ensure consistent placement. | 6-9-27 |
| 54) If a support is misplaced or slips, this is 'no vault' and another trial will be allowed. Warm-up for athlete(s) entering PV after sixty (60) min have elapsed get two (2) min to warm-up w/o crossbar or bungee at height change. If more than 1 athlete they each get 2 min., not aggregated, must make 1 attempt in 1 min. | 6-8-4 |
| 55) min to warm-up w/o crossbar or bungee at height change. If more than 1 athlete they each get 2 min., not aggregated, must make 1 attempt in 1 min. | 6-8-6 |
| TIES: | p.44-45 |
| 56) 1st tie breaker: fewest number of misses at tied height is winner. | 6-3-2b1 |
| 57) 2nd tie breaker: fewest number of misses during competition is the winner. | 6-3-2b2 |
| 58) Passed trials shall not count as misses. 3rd tie breaker FOR 1st PLACE ONLY: Allow one (1) more trial at FAILED height. Tied jumpers both miss → lower the bar 3" and allow one (1) trial. | 6-3-2b3 |
| 59) Tied jumpers both clear → raise the bar 3" and allow one (1) trial. Continue to raise/lower the bar and allow one (1) trial until winner is determined. | 6-3-2b4b |
| 60) Ties BELOW 1st place: Add points for places; Divide by number of tied competitors. | 6-3-4 |

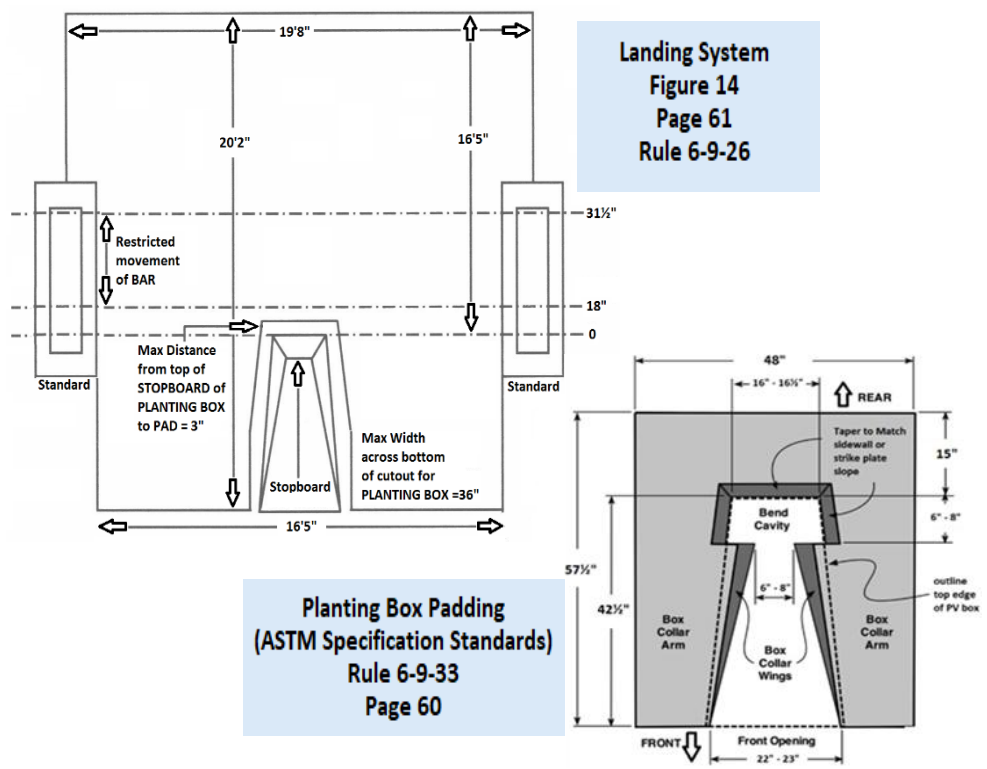

UNIFORM GUIDELINES
PROACTIVE CHECK-IN

Athletes may fix their uniforms / tuck in tops before competition begins.

▶ **INVISIBLE ... And OK**

Socks; Arm Warmers; HAIR CONTROL;
Visor/Cap; Arm Warmers; Waistband Logo;
Gloves in HJ & LJ.



▶ **VISIBLE ... And OK**

Ski Band; Knit Watch Cap; One Mfg Logo/garment ≤ 2 1/4 IN SQ;
Sunglasses; Medic Alert Bracelet; Sweatband ≤ 2" wide;
Jewelry; Wrist Watch; Ball Cap.



▶ **VISIBLE ... But NOT OK**

Hazardous Jewelry; Offensive Body Adornment/Tattoo; Bare Midriff;
NO SHOES at the start of a race or during a field event; GLOVES in SP/
DT/PV/RELAYS; Tops w/Knots.



FAILURE TO REPORT

A contestant who fails to report before the start of competition shall not be allowed to participate in the event (**Rule 4-1-3**).
Contact the REFEREE.



ATHLETES EXCUSED TO ANOTHER EVENT

- ➔ **ASK** Athletes at check-in if they have other events.
- ➔ **TIME LIMITS** - Know the procedure set by the GAMES COMMITTEE.
- ➔ **COMMON SENSE** must prevail.
- ➔ **RE-ORDER FLIGHTS** to facilitate athletes competing in other events.
Athletes may choose to 1) move ahead in the order of competition or 2) take consecutive trials before being excused.
- ➔ **BE PROACTIVE** - Allow a teammate or coach to report to a field event and stand by during the time a competitor has left to compete in another event.
The stand-in's presence validates the entry of the excused athlete.
- ➔ **TIME-STAMP TWICE** - When excused athlete 1) LEAVES and 2) RETURNS.
- ➔ **FINALS** - DO NOT CALL an athlete who is legally excused to another event.



Continue the competition.

- ➔ The competitor with the best prelim mark may wait until any excused competitors have taken all their trials to take the FINAL attempt of the competition [**Rule 6-2-3**].

ATHLETES EXCUSED TO ANOTHER EVENT -- HAS NOT RETURNED

▶ **Shot Put; Discus Throw; Long Jump**

If an athlete has not returned & all others have completed trials ...
ANNOUNCE: All remaining throws or jumps must be completed.

Example: "In 10 minutes (or another pre-defined time) the venue will close."

▶ **High Jump; Pole Vault**

If an athlete has not returned and all others have cleared the height ...
ANNOUNCE: The bar will soon be raised.

Example: "In 5 minutes (or another pre-defined time) the bar will be raised to the next height."

NOTE: Unused attempts will be marked as a pass and may be used at the new height.



JUDGES TERMINOLOGY -- ALL EVENTS

CALLING TRIALS

"James **UP**" | "William **ON DECK**" | "Thomas **ON HOLD**."

When they are '**UP**,' Competitors must be ready - not getting ready.

▶ **Good Trial**

☐ "**Fair**" -or- **WHITE FLAG** (Using FLAGS is recommended)

▶ **Signal: Remaining Time Allowed**

🟡 "**15 Seconds**" -or- **YELLOW FLAG** (Using FLAGS is recommended)

▶ **Failed Trial**

🔴 "**Foul**" -or- **RED FLAG** (Using FLAGS is recommended)



RECORDING TRIALS

○ ➔ **CLEARED HEIGHT** X ➔ **FAILED ATTEMPT** - ➔ **PASS**

MEASURING TRIALS

- ▶ LJ | HJ | PV | SP ➔ MEASURE to nearest lesser 1/4-IN or CM.
- ▶ HJ | PV ➔ MEASURE heights before RECORD ATTEMPTS.
- ▶ DT ➔ MEASURE to nearest lesser INCH or CM.
- ▶ LJ ➔ MEASURE at the TAKEOFF BOARD.



ORDER OF COMPETITION

- ▶ **High Jump; Pole Vault - "5 Alive" format.**
When less than 9 remain at a height, ALL will move to a single continuing flight.
- ▶ **Discus Throw; Shot Put**
Order may be changed to allow for participation in other events.

COMMUNICATION DURING COMPETITION

- **AVOID ANNOUNCING** - the name of an athlete or school who's AWOL.
- **CLEARLY ARTICULATE** - performance [height/distance] after each trial.
- **RECORD BEST PERFORMANCE** - CAREFULLY [in *BESTS COLUMN*.]
- **ANNOUNCE & CIRCLE** - *BEST* performances after final attempts.
- **ANNOUNCE** at conclusion - order of finish & best performance.
- **SEND RESULTS** - to the Press Box Announcer.



ADVANCING QUALIFIERS TO FINALS

- ▶ **DOUBLE-CHECK** the score sheet.
- ▶ **CONFIRM** the FINALISTS before announcing.
- ▶ **SEND FINALS INFO** to the Press Box Announcer.
- ▶ **ANNOUNCE** ➔ 1) Finalists & top prelim mark.
2) The time at which finals begin.

RE-WRITE the FINALISTS with best prelim mark on another sheet in the order of finals competition.

- ▶ Competitors may view video in a coach's box

| ENGLISH | | TARGET HEIGHT | | RECORD | | DATE | | SECURITY # 00 000 | |
|---------|------|---------------|------|--------|------|------|------|-------------------|------|
| DATE | TIME | 1 | 2 | 3 | 4 | 5 | 6 | 7 | 8 |
| 1 | 01 | 2.70 | 2.70 | 2.70 | 2.70 | 2.70 | 2.70 | 2.70 | 2.70 |
| 2 | 02 | 2.70 | 2.70 | 2.70 | 2.70 | 2.70 | 2.70 | 2.70 | 2.70 |
| 3 | 03 | 2.70 | 2.70 | 2.70 | 2.70 | 2.70 | 2.70 | 2.70 | 2.70 |
| 4 | 04 | 2.70 | 2.70 | 2.70 | 2.70 | 2.70 | 2.70 | 2.70 | 2.70 |
| 5 | 05 | 2.70 | 2.70 | 2.70 | 2.70 | 2.70 | 2.70 | 2.70 | 2.70 |
| 6 | 06 | 2.70 | 2.70 | 2.70 | 2.70 | 2.70 | 2.70 | 2.70 | 2.70 |
| 7 | 07 | 2.70 | 2.70 | 2.70 | 2.70 | 2.70 | 2.70 | 2.70 | 2.70 |
| 8 | 08 | 2.70 | 2.70 | 2.70 | 2.70 | 2.70 | 2.70 | 2.70 | 2.70 |
| 9 | 09 | 2.70 | 2.70 | 2.70 | 2.70 | 2.70 | 2.70 | 2.70 | 2.70 |
| 10 | 10 | 2.70 | 2.70 | 2.70 | 2.70 | 2.70 | 2.70 | 2.70 | 2.70 |
| 11 | 11 | 2.70 | 2.70 | 2.70 | 2.70 | 2.70 | 2.70 | 2.70 | 2.70 |
| 12 | 12 | 2.70 | 2.70 | 2.70 | 2.70 | 2.70 | 2.70 | 2.70 | 2.70 |
| 13 | 13 | 2.70 | 2.70 | 2.70 | 2.70 | 2.70 | 2.70 | 2.70 | 2.70 |
| 14 | 14 | 2.70 | 2.70 | 2.70 | 2.70 | 2.70 | 2.70 | 2.70 | 2.70 |
| 15 | 15 | 2.70 | 2.70 | 2.70 | 2.70 | 2.70 | 2.70 | 2.70 | 2.70 |
| 16 | 16 | 2.70 | 2.70 | 2.70 | 2.70 | 2.70 | 2.70 | 2.70 | 2.70 |

MANAGING APPEALS / QUESTIONS (ex. Improper attire / implement)

- 1) Record the performance.
- 2) Don't announce results if there is a question/appeal.



SHOT PUT & DISCUS THROW

Throwing Sector Set-Up

from the NFHS 2026 Track & Field Rule Book -- Appendix B: p.88-89

The SECTOR in the **SHOT PUT** will be 34.92 degrees. **Rule 6-9-5**
 The SECTOR in the **DISCUS** will be 34.92 degrees. **Rule 6-9-9**

Sector Angle Formula: BASE = 0.6 x LEG

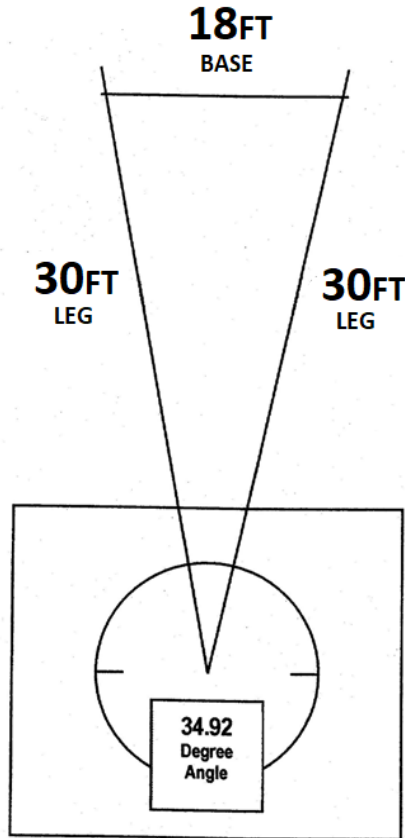

Trials at Regional & State Final Meets

from the MHSAA

In the [SHOT PUT and DISCUS THROW] each competitor shall be allowed three preliminary trials.
 In the finals, each qualifier is awarded three additional trials.

[Rule 6-2-17]

At MHSAA Regional and State Final meets: these trials shall be taken in the sequence 1-1-1.

from the 2026 MHSAA Coaches Guidebook p.20

► **PARTICIPATION:** Athlete may participate in any 3 track and/or field events.

► **DUAL MEET SCORING:** 5-3-1 (INDIVIDUAL); 5-0 (RELAYS)
 By prior agreement, schools may score 4 places: 5-3-2-1; and 5-0 (RELAYS)

► **RUNNING EVENTS:** Boys run 1st [even year] | Girls run 1st [odd year]

Note 1:

By mutual consent: DISTANCES may be shortened or EVENTS may be eliminated.

Note 2: 55m Hurdles: 5 hurdles | Boys Height-33" | Girls Height-30"

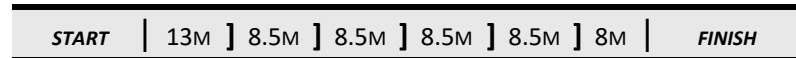

Note 3: 200m Hurdles: 5 Hurdles | Boys Height-30" | Girls Height-30"



Note 4:

Running Events: One false start shall be permitted. (with a warning)

► **Junior High / Middle School Order of Events - MHSAA Approved List**

Running Events

| | EVEN YEAR | ODD YEAR |
|----|------------------|-----------|
| | Boys 1st | Girls 1st |
| 1 | 4x800M Relay | |
| 2 | 55M (33"/30") LH | |
| 3 | 100M | |
| 4 | 4x200M Relay | |
| 5 | 1600M | |
| 6 | 4x100M Relay | |
| 7 | 400M | |
| 8 | 70M | |
| 9 | 800M | |
| 10 | 200M (30") LH | |
| 11 | 200M | |
| 12 | 3200M | |
| 13 | 4x400M Relay | |

Field Events

| EVEN YEAR | ODD YEAR |
|-----------|----------|
| Girls 1st | Boys 1st |
| SP HJ | PV LJ |

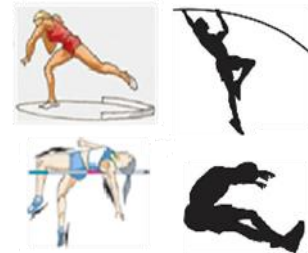

Junior High / Middle School Field Event Specifications

from the NFHS 2026 Rule Book p.79



Article a) DISCUS THROW

- ➔ Boys Discus: 1.0 Kg
- ➔ Girls Discus: 1.0 Kg



Article b) SHOT PUT

- ➔ Boys Shot: 4.0 Kg
- ➔ Girls Shot: 6.0 Pounds

Article c) LONG JUMP

The **FOUL LINE** in the LONG JUMP should be approximately 8-feet from the NEAR EDGE of the landing pit. ➔

